

DIRETO

BELT AND CALIBRATION

ELITE
CHANGE YOUR RIDE

INSTRUCTIONS

IT ISTRUZIONI
EN INSTRUCTIONS

IT

CINGHIA + GALOPPINO

Qui di seguito è possibile trovare il link per effettuare la sostituzione della cinghia e della puleggia nera con il relativo supporto galoppino:

<https://youtu.be/JOYVSZ3yrX4>



Si prega di tenere in considerazione i seguenti punti:

- Non piegare eccessivamente la nuova cinghia durante la sostituzione.
- Una volta sostituita la cinghia è necessario procedere al suo corretto tensionamento.

La procedura di tensionamento viene effettuata monitorando il valore di offset indicato sull'etichetta argentata applicata sotto al rullo.

Un video dedicato è disponibile qui:

<https://youtu.be/fl-mXkwP-u0>



Se dovesse necessitare di ulteriori informazioni, l'invitiamo a contattarci e provvederemo a fornirLe assistenza.

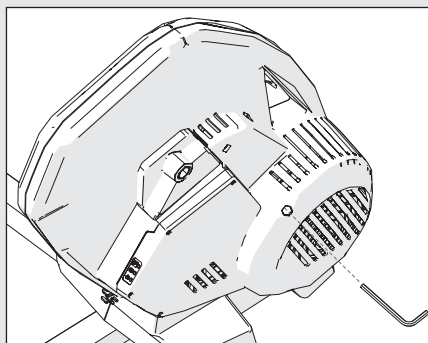

ATTENZIONE: L'utilizzo dell'avvitatore elettrico per il serraggio della vite che blocca il sistema di tensionamento della cinghia potrebbe danneggiare il prodotto (max torque 2 Nm).

EN

BELT +BLACK PULLEY

Here below the link with the instructions in order to correctly replace both belt and black pulley:
<https://youtu.be/JOVVSZ3yrX4>



Please note the following things:

- Please don't bend or crimp the new belt during the substitution.
- Once the belt has been replaced it is mandatory to correctly tighten it

Belt tightening procedure is done by following the offset value which is placed on the silver label sitted underneath the hometrainer.

Watch the dedicated video:

<https://youtu.be/fl-mXkwP-uo>



Should you need further assistance, feel free to contact us.

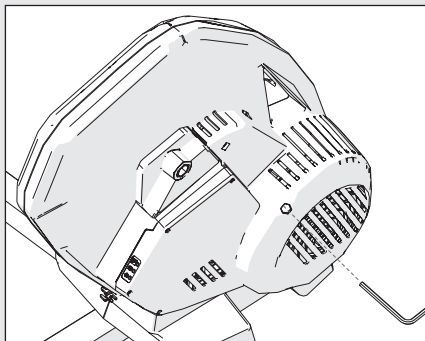

CAUTION: The use of an electric screwdriver for tighten the locking screw may damage the product (max torque 2 Nm).

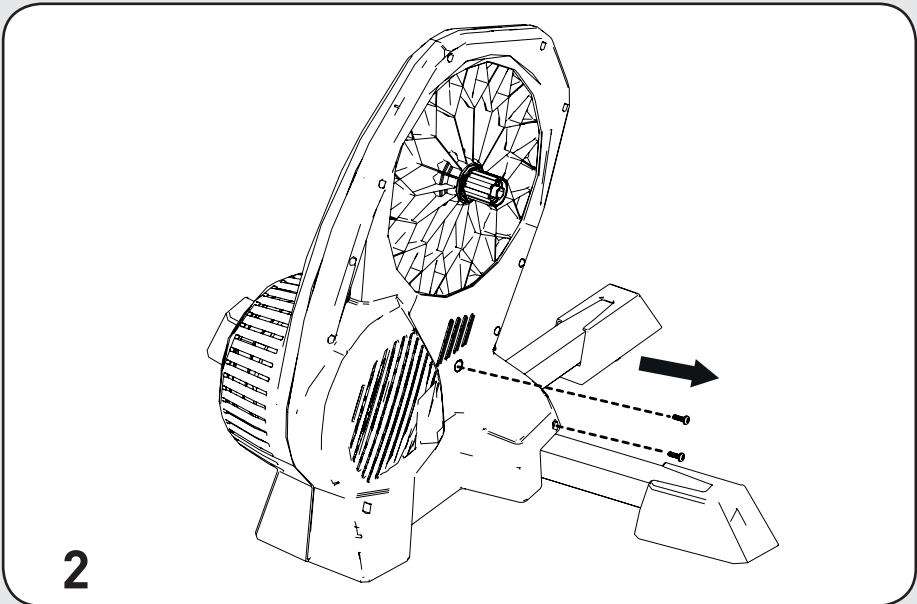
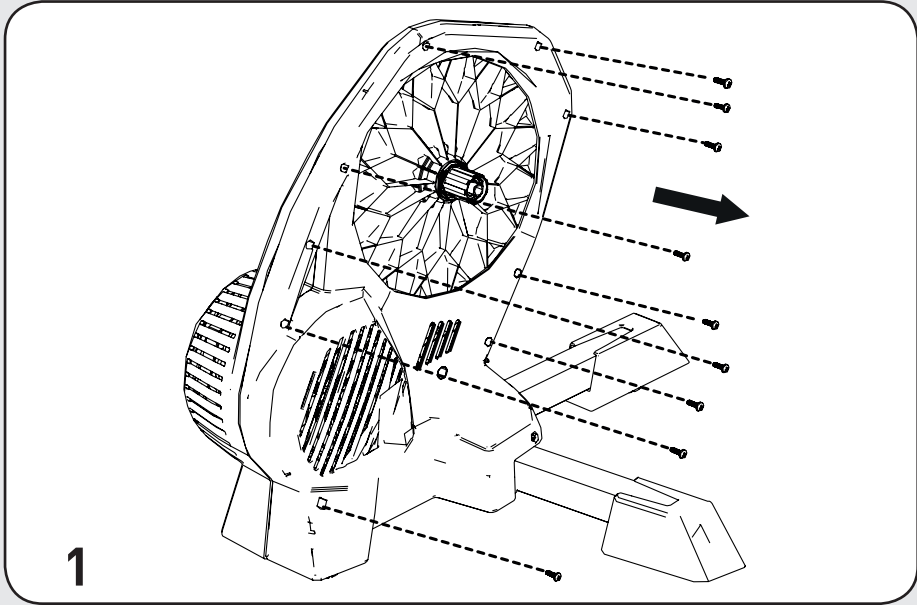

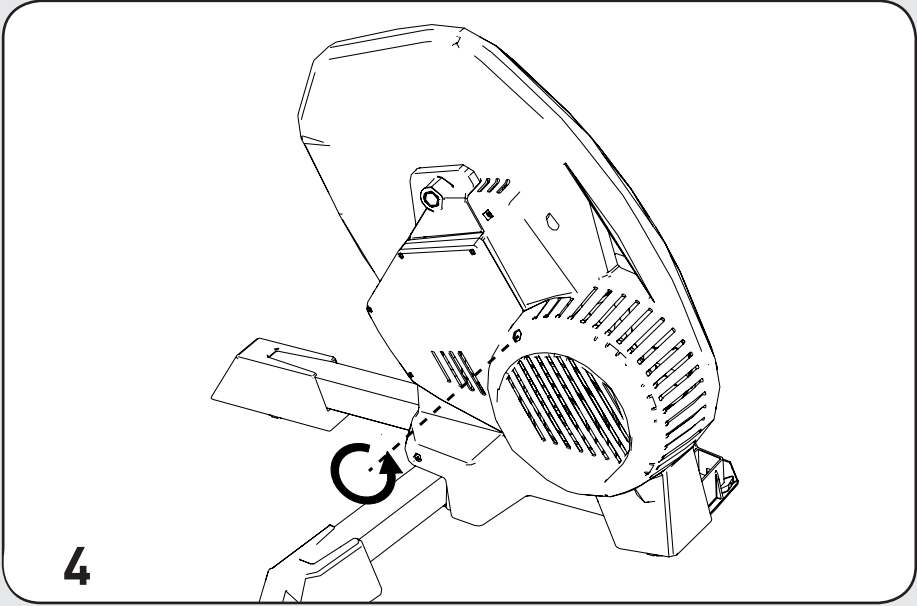
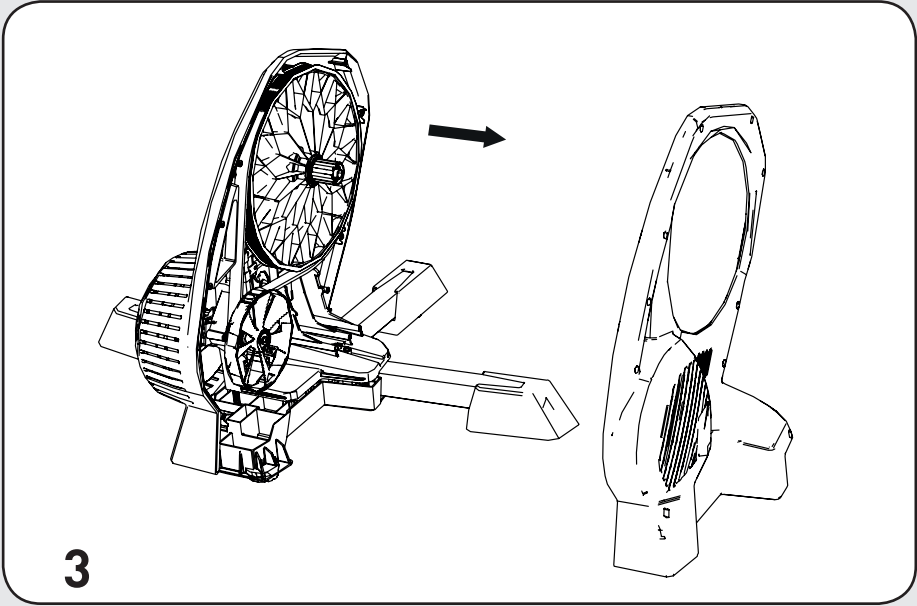

svitare completamente

completely unscrew

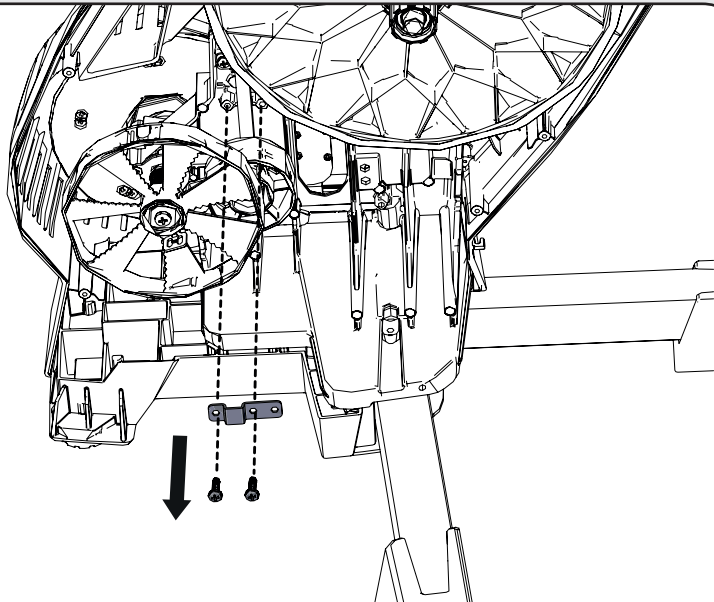
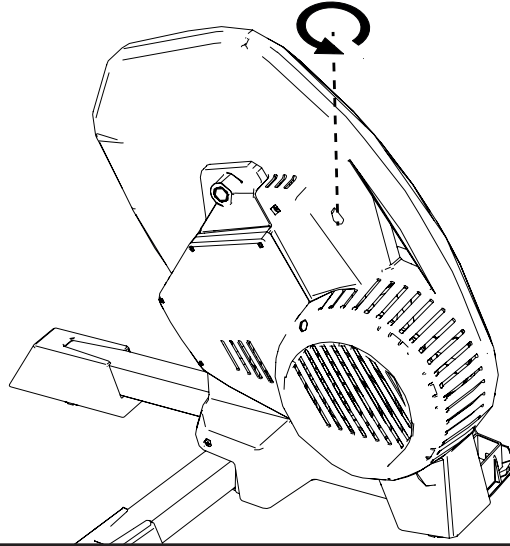

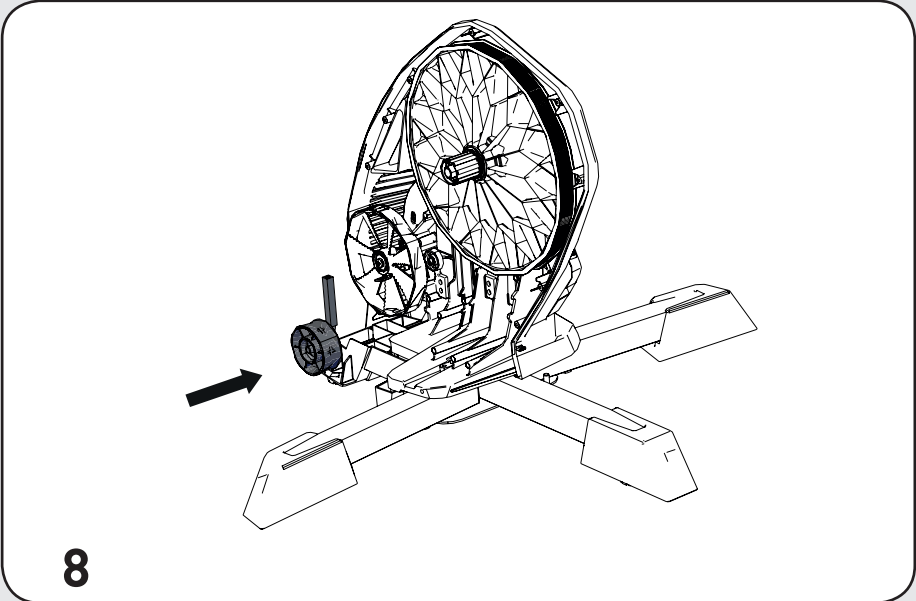
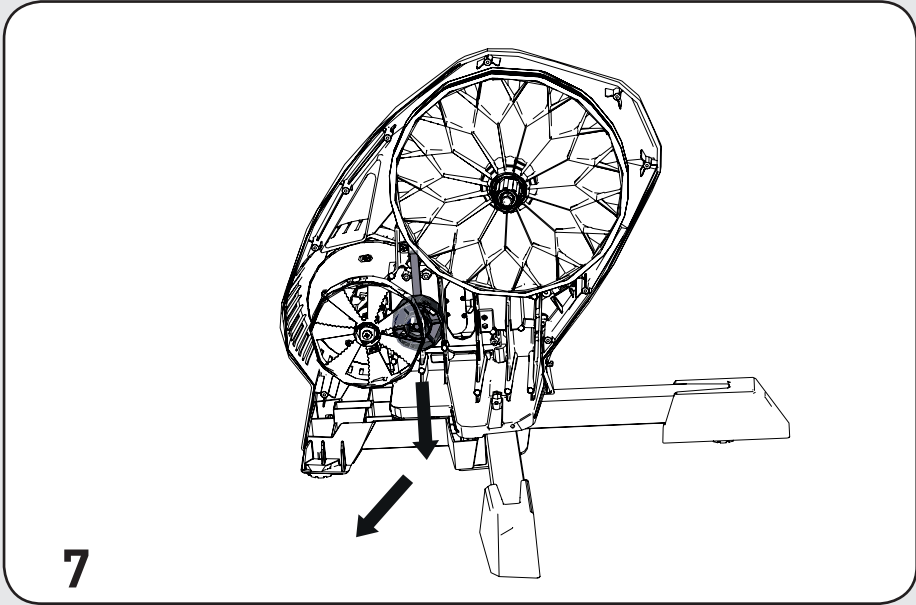

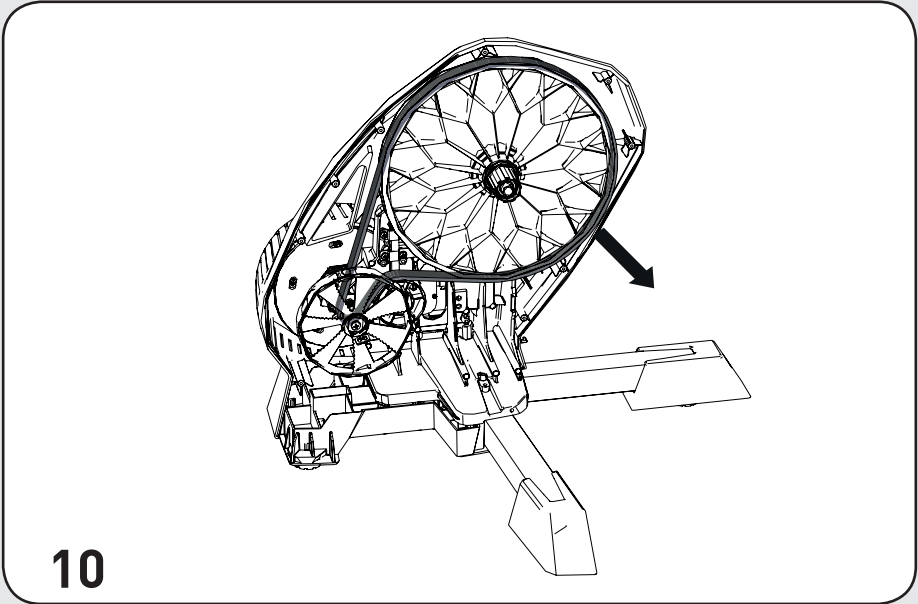
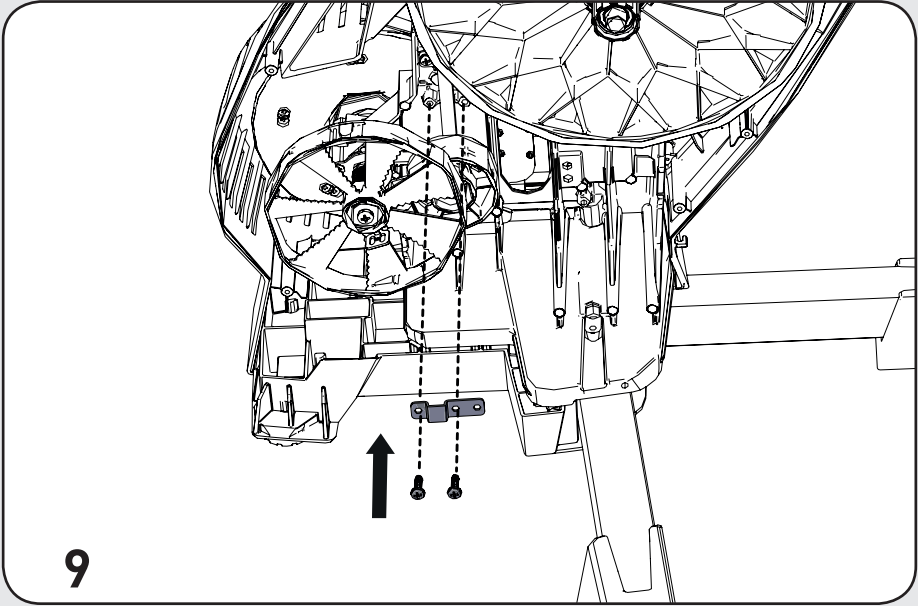

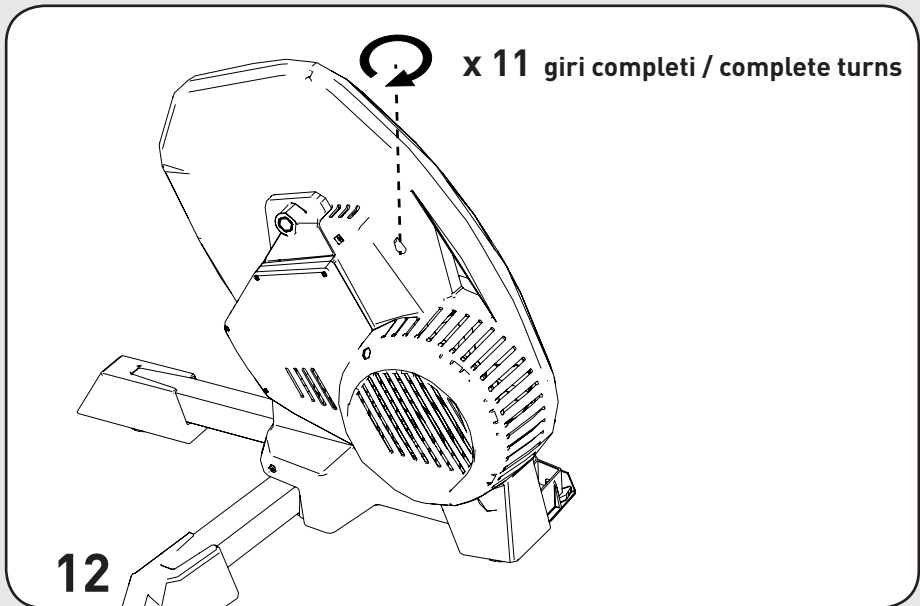
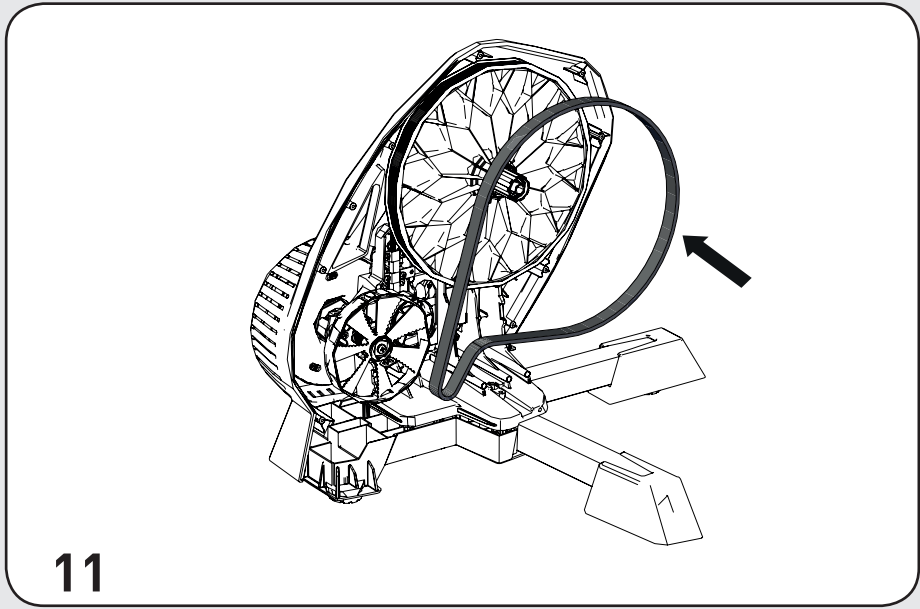

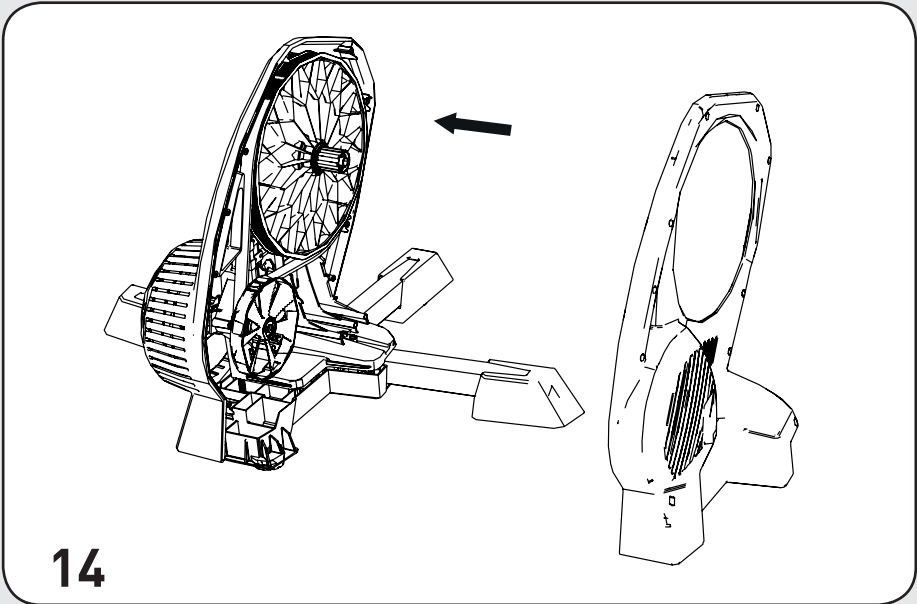
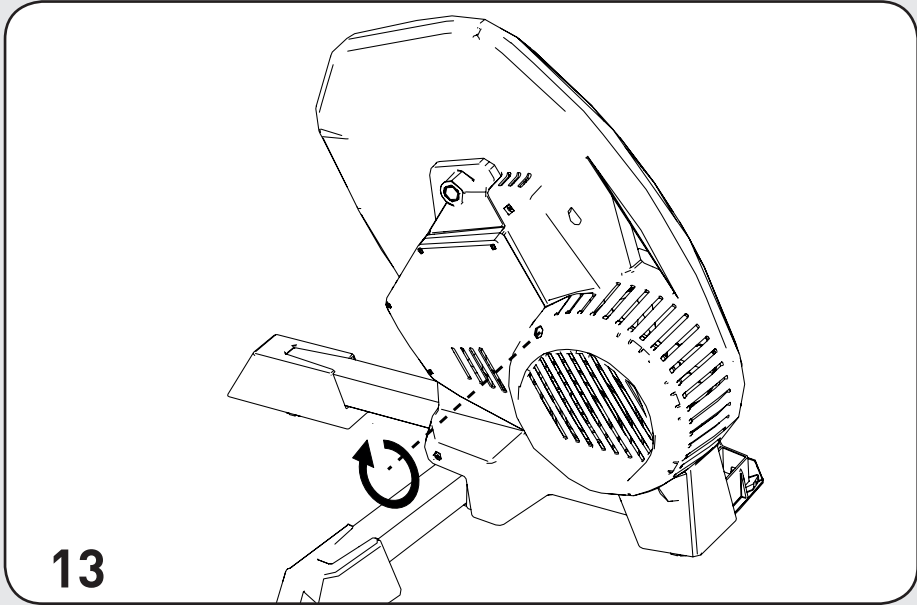

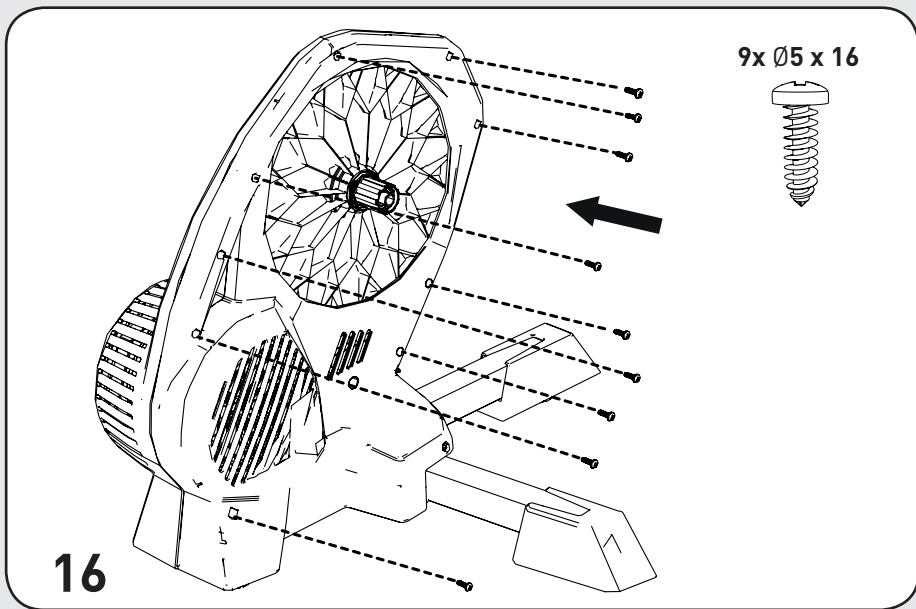
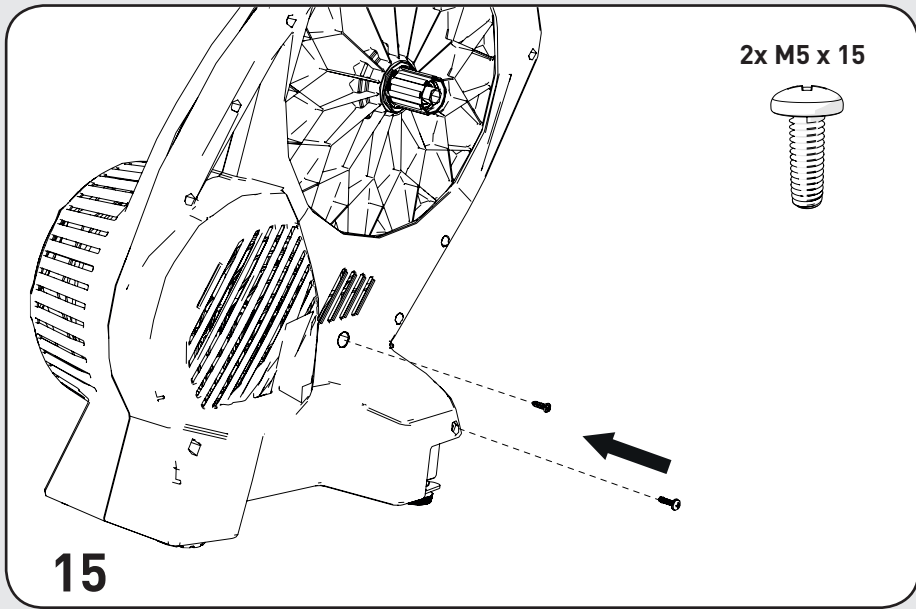

PROCEDURA DI CALIBRAZIONE

1) cerca il codice OFFSET situato sotto al rullo;



2) apri My E-Training:

Parametri/
Configurazione/
Calibrazione del Trainer;

3) iniziare a pedalare:

a) se il numero di calibrazione coincide con il codice di OFFSET (± 1), puoi usare DIRETO

b) se il numero di calibrazione non coincide con il codice di OFFSET, ripetere la procedura di calibrazione:

- allentare il blocco (fig. 4);
- serrare la vite di tensionamento (fig. 12) (mezzo giro di tensionamento corrisponde a circa un punto di Offset);
- chiudere il blocco (fig. 13);
- iniziare a pedalare;
- controllare il numero di calibrazione:

se questo coincide con il codice OFFSET (± 1), puoi usare DIRETO; se non coincide, ripetere la procedura di calibrazione.

ESEMPIO:

Se il numero di OFFSET è 6395, e dopo il cambio cinghia e il primo tensionamento di 11 giri si raggiunge un numero di calibrazione di 6392, per raggiungere i 3 punti di offset necessari avvitare in senso orario di 1 giro e mezzo (3 mezzi giri = 3 punti offset)

PROCEDURE OF CALIBRATION

1) Find OFFSET code placed on the back of the trainer;



2) open My E-Training:

Parametres/
Configuration/
Trainer calibration

3) start pedaling

a) if your calibration number coincides with the OFFSET code (± 1),
you can use your DIRETO

b) if your calibration number does NOT coincides with the OFFSET code,
you must repeat the procedure of calibration:

- unlock the tightner screw lock (pic. 4);
- tighten the tensioning screw (pic. 12), 1 offset point equals a half-turn of tension);
- lock the tightner screw lock (pic. 13);
- start pedaling;
- check calibration number:

if this concides with the OFFSET code (± 1), you can use your DIRETO;

if this does NOT coincides, repeat the procedure of calibration

CASE EXAMPLE:

If your OFFSET code is 6395, and you are reaching a calibration number of 6392 with the belt replacement and the 11-turn tensioning, then you need to turn the screw clockwise of 1 turn and a half to get the 3 residual offset points (3 half turns = 3 offset points)

ELITE

CHANGE YOUR RIDE



ELITE S.R.L.

VIA FORNACI, 4
35014 FONTANIVA
PADOVA - ITALY

PHONE +39 049 594 0044

E-MAIL: INFO@ELITE-IT.COM

ELITE-IT.COM



code 6054744